

PRELIMINARY
SPECIFICATIONS

MOVE THE WORLD FORWARD  MITSUBISHI
HEAVY
INDUSTRIES
GROUP

AXiA XL

SBR12N2TF Series

STAND-IN STACKERS WITH TELESCOPIC FORKS

1.2 tonnes

BIGGER REACH EFFICIENT STACKING

AXiA stand-in stackers can help you optimise warehouse space efficiency. AXiA XL models with telescopic forks enable more flexible handling of long loads and work with double deep racking setups. Double deep racking stores four pallets between aisles, reducing storage cost per square meter by up to 17% and increasing pallet locations by 25–30%.

SPECIFICATIONS

SBR12N2TF



**WHEN
RELIABILITY IS
EVERYTHING...**

 **MITSUBISHI
FORKLIFT TRUCKS**

AXiA XL

SBR12N2TF Series

STAND-IN STACKERS WITH TELESCOPIC FORKS

1.2 tonnes



BRAKES

- **High-efficiency regenerative braking**
This gives more effective control and reduces brake wear.

DRIVE

- **Powerful AC drive motor**
High torque for greater efficiency. No carbon brushes mean lower servicing requirements.
- **Intelligent Cornering System**
The truck senses the angle of a turn and reduces speed early for maximum stability and accurate, positive cornering.
- **Automatic Speed Reduction**
Drive speed is automatically limited when forks are above 1.2m to allow higher capacities above that height.

ELECTRICAL AND CONTROL SYSTEMS

- **Built-in Li-ion battery**
Fast opportune charging removes the need for extra batteries and allows 24/7 operation. (Junior chassis only) (Option)
- **Convenient charging**
An extra battery plug on the outside of the truck allows for easy charging without needing to disconnect the internal battery plug. (Lead acid batteries).
- **Combi controller lift system**
Fingertip control for speed regulated lifting and proportional valve for lowering.
- **Enhanced Stability System (ESS)**
4-point chassis for maximum stability, drive speed is reduced when forks are lifted, and acceleration is reduced when steering angle exceeds 45 degrees.

FORKS AND MAST

- **Level Assistance System**
Automatically detects the operator's intention and automatically stops when the forks are at precisely at the right level. (Option)
- **Laser positioning guide**
Aligning the red laser line with the centre of the pallet pocket allows the driver to quickly ensure the forks are in the desired position. (Option)
- **Robust, clear view mast**
Optimised design means excellent visibility of the forks and load.
- **Exceptionally smooth 'no knock' transition between mast stages**
Vulkollan dampers ensure quieter movement over the lift range.
- **Smooth landing of the fork carriage**
Hydraulic attenuation in the free-lift cylinder makes this much quieter.
- **Hydraulic telescopic forks**
Speed regulated for greater precision and safer operation.
- **Longer reach**
Telescopic forks allow for handling of longer goods and greater reach across lorry beds.
- **Wide Straddle Legs**
These feature single wheels as standard with tandem wheels as an option. 750mm width standard, 950mm option.

FRAME AND BODY

- **Robust chassis**
Built for intensive operations, with great inherent strength and high residual capacities. Designed to enclose the operator within for extra safety.
- **Strong battery lock**
Simple and safe. Battery lock can only be unlocked when battery plug is disconnected. Battery plug can only be reconnected if battery is locked.
- **Excellent ground clearance**
Easy and safe handling on loading docks and ramps.
- **RapidAccess features**
These allow quick and easy entry to all areas for checks and maintenance.
- **Waterproof wiring and connectors**
Sealed compartment prevents system failure and corrosion from water and dust.
- **Overhead guard pillars**
Protection for the operator while still offering excellent visibility.



For more information on AXiA XL please visit our website



mft2.eu/axiaxlsbr

AXiA XL

SBR12N2TF Series

STAND-IN STACKERS WITH TELESCOPIC FORKS

1.2 tonnes



HYDRAULICS

- **Smooth, quick lifting and lowering**
High levels of control and productivity. Low noise means less fatigue for the operator over long shifts.

OPERATOR COMPARTMENT AND CONTROLS

- **Optical Presence Sensor**
This locks all movement of the truck and its mast if the operator is not present. Driver can lift foot slightly without brakes automatically engaging, reducing muscle stress.
- **Plenty of storage space**
Storage for on-board essentials, putting clipboard, mobile phone, drinks bottle and pen all within easy reach.
- **Ultra-low step height**
Operators stay more productive throughout shifts thanks to easy on/off access.
- **Ergo Forks Trailing Control**
When working with forks trailing, an additional speed control allows an operator to stand in a more comfortable and ergonomic forward-facing position while travelling. (Option)

STEERING SYSTEM

- **Fully adjustable steering wheel**
Height and distance are ergonomically adjustable to reduce strain and lower risk of RSI.
- **360-degree steering**
The operator can keep the truck in constant motion - saving seconds on every turn. (Option)
- **Dynamic Power Steering**
Smooth, precise control with minimum effort offering maximum comfort and stability at top speed.



For more information on AXiA XL please visit our website





AXIA XL

AVAILABLE LI-ION SYSTEMS

MAKE YOUR FORKLIFT GO EVEN FURTHER



Tried, tested and proven in the field, lead-acid batteries have been the long-standing choice for companies employing electric lift trucks. However, with long charging times, demanding maintenance requirements, the need for extra batteries, and high risk of operator misuse, day-to-day use can be a challenge.

Fortunately, there's a new battery system on the block: Li-ion from Mitsubishi Forklift Trucks.

Designed to meet your business' demands — including multi-shift (24/7) operations — without the need for spare batteries, our high-performance Li-ion battery system is up to 30% more efficient than lead-acid counterparts. Plus, it's virtually error-proof, thanks to its ultra-low-maintenance design which prevents cell damage.

- **Gas-emission free**
No need for air ventilation.



- **Exceptional high battery and charger efficiency**
State-of-the-art technology delivers up to 30% more power efficiency than lead-acid batteries.
- **Maintenance-free design**
No need for daily checks and water re-fills. This reduces the risk of operators damaging cells and reducing their lifetime. Needs a full charge each week to activate cell balancing.
- **No need for spare batteries or charging room**
You can save both space and costs in multi-shift applications, maximising profitability.
- **Quick charge capabilities**
Just 15 minutes is all your battery needs to keep your truck going for a few more hours. It only takes 1 to 2 hours to fully charge a completely discharged battery.
- **Higher sustained voltage**
This gives more consistent lifting and driving performance — particularly noticeable towards the end of a shift.
- **Multiple safety features**
This includes circuit protection, deep-discharge and overcharge protection, and individual cell temperature and voltage monitoring.
- **On-the-go performance and monitoring**
The system's integrated monitoring system has an easy-to-read display unit.
- **Wide choice of battery and charger capacities**
The most suitable power supply can be matched to the exact requirements of a specific application.



Clean Li-ion batteries are ideal for sensitive environments such as those in the food or packaging industries.



Fully integrated Li-ion battery

Features a sophisticated CANbus communication and an automatic ON/OFF synchronization between battery and truck. Battery level, notifications and alarms are integrated into the truck display, to secure clear and easy overview for the truck operator.

For more information on Li-ion please visit our website



VDI - PERFORMANCE & DIMENSIONS

CHARACTERISTICS			
1.1	Manufacturer		Mitsubishi Forklift Trucks
1.2	Manufacturer's model designation		SBR12N2TF
1.3	Power source		Battery
1.4	Operator type		Stand-in
1.5	Load capacity	Q	kg 1200
1.6	Load center distance	c	mm 600
1.8	Load wheel axle to fork face (forks lowered)	x	mm 714
1.9	Wheelbase	y	mm 1540 ²⁾
WEIGHT			
2.1b	Truck weight without load, with maximum battery weight		kg 2068
2.2	Axle loadings with nominal load & maximum battery weight, drive / load side		kg 1468 / 1800
2.3	Axle loadings without load & with maximum battery weight, drive / load side		kg 1448 / 620
WHEELS, DRIVE TRAIN			
3.1	Tyres: PT = Power Thane, Vul = Vulkollan, P = Polyurethane, N = Nylon, R = Rubber drive / load side		Vul / Vul
3.2	Tyre dimensions, drive side		mm 250 x 105
3.3	Tyre dimensions, load side	ø	mm 150 x 55
3.4	Castor wheel dimensions (diameter x width)		mm 150 x 55
3.5	Number of wheels, load / drive side (x = driven)		2 / 1x + 2 ¹⁾
3.6	Track width (center of tyres), drive side	b10	mm 651
3.7	Track width (center of tyres), load side	b11	mm 850 / 1050
DIMENSIONS			
4.2a	Height with mast lowered	h1	mm see tables
4.2b	Height	h1	mm see tables
4.3	Free lift	h2	mm see tables
4.4	Lift height	h3	mm see tables
4.5	Height with mast extended	h4	mm see tables
4.6	Initial lift	h5	mm -
4.7	Height to top of overhead guard	h6	mm 2310
4.8	Seat- or stand height	h7	mm 230
4.10	Height of support legs	h8	mm 110
4.15	Fork height, fully lowered	h13	mm 65
4.19	Overall length	l1	mm 2229 ²⁾
4.20	Length to fork face	l2	mm 1029 ²⁾
4.21	Overall width	b1	mm 950 / 1150 ⁸⁾
4.22	Fork dimensions (thickness, width, length)	s/e/l	mm 57 / 169 / 1200
4.23	Fork carriage to DIN		FEM 3/A
4.24	Fork carriage width	b3	mm 820
4.25	Outside width over forks (minimum / maximum)	b5	mm 578 / 842
4.26	Inner width of support legs	b4	mm 750 / 950 ⁸⁾
4.28	Mast reach travel	l4	mm 850 ³⁾
4.32	Ground clearance at center of wheelbase, (forks lowered)	m2	mm 40
4.33a	Working aisle width (Ast) with 1000 x 1200 mm pallets, load crosswise	Ast	mm 2623
4.34a	Working aisle width (Ast) with 800 x 1200 mm pallets, load lengthwise	Ast	mm 2587
4.35	Turning radius	Wa	mm 1758
4.37	Truck length including support legs	l7	mm 1848 ²⁾
PERFORMANCE			
5.1	Travel speed, with / without load		km/h 8.0 / 8.0
5.2	Lifting speed, with / without load		m/s 0.15 / 0.26 ⁴⁾
5.3	Lowering speed, with / without load		m/s 0.38 / 0.38 ⁴⁾
5.8	Maximum gradeability with / without load		% 7.8 / 7.8
5.9	Acceleration time (10 metres) with / without load		s 6.5 / 5.5
5.10	Service brakes (mechanical / hydraulic / electric / pneumatic)		Electric
ELECTRIC MOTORS			
6.1	Drive motor capacity (60 min. short duty)		kW 2.7
6.2	Lift motor output at 15% duty factor		kW 8.0 ⁵⁾
6.3	Battery to DIN		DIN-cells
6.4	Battery voltage/capacity at 5-hour discharge		V/Ah 24 / 465 ⁶⁾
6.5	Battery weight		kg 330-400 ⁶⁾
6.6a	Energy consumption according to EN16796 cycle		kWh/h 0.87 ⁷⁾
MISCELLANEOUS			
8.1	Type of drive control		AC
10.7	Level of noise at the ear level of the driver according to EN 12 053:2001 and EN ISO 4871 in work LpAZ		dB(A) <70
10.7.2	Whole-body vibration (EN 13 059:2002)		see instruction handbook
10.7.3	Hand-arm vibration (EN 13 059:2002)		see instruction handbook

AXIA XL

SBR12N2TF Series

STAND-IN STACKER WITH TELESCOPIC FORKS

1.2 tonnes

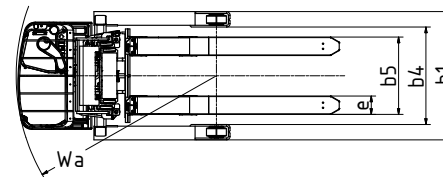
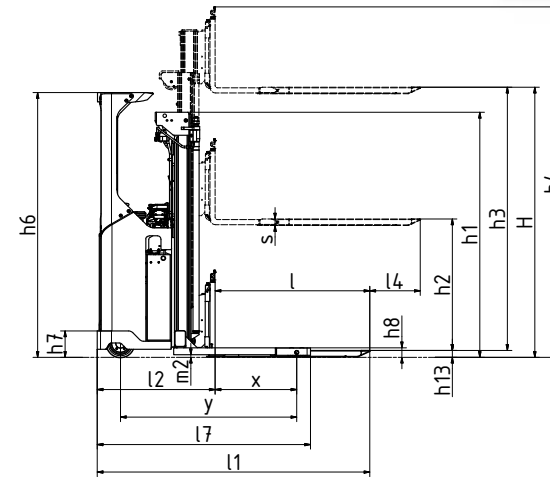

Ast = Working aisle width
 Ast3 = Working aisle width (b12 < 1000 mm)
 $Ast = Wa + \sqrt{(l6 - x)^2 + (b12 / 2)^2} + a$
 Ast3 = $Wa + l6 - x + a$
 Wa = Turning radius
 l6 = Pallet length
 x = Load wheel axle to fork face
 b12 = Pallet width
 a = Safety clearance = 2 x 100 mm

MAST TYPE	h3+h13 mm	h1 mm	h4 mm	h2+h13 mm
SBR12N2TF				
DTFV / TREV	4800	2150	5750	1225
	5400	2350	6350	1425
	5700	2450	6650	1525
	6300	2650	7250	1725

All dimensional values, weights and measures vary according to configuration

- 1) 4-point design with twin assembly drive side castor wheels
- 2) When Senior (BC775) chassis then add 104 mm
- 3) Telescopic forks reach travel, optional reach 450-1000
- 4) Standard motor, not sufficiently tested with the 8.0 kW heavy-duty option yet
- 5) With heavy-duty lift motor, standard is 4.0
- 6) With Senior chassis, 24V / 560-775Ah and 460-610 kg
- 7) This is a reference test value that varies according to model, config and usage pattern
- 8) There are two standard straddle/support legs widths available to choose from (ref. b1/b4)

STANDARD EQUIPMENT & OPTIONS

- = Standard
- = Option

	SBR12N2TF
GENERAL	
Wide straddle legs for handling of closed load carriers	●
Telescopic forks for extended reach in handling of e.g. double-deep stacking and closed load carriers	●
Standard display incl. hour meter and battery discharge indicator (BDI)	●
Key switch entry	●
Electric power steering, with fully adjustable steering wheel	●
Automatic straight steering at start-up	●
Adaptive cornering control	●
Speed regulated lift motor and proportional valve for lowering	●
Tandem load wheels Vulkollan	●
Overhead guard (OHG)	●
Adjustable armrest	●
Adjustable steering wheel	●
Storage compartment under armrest	●
Writing desk with paper clip	●
Battery on rollers	●
POWER SOURCE	
Li-ion batteries*	●
Lead acid batteries	●
ENVIRONMENT	
Chill store design, down to -10°C	●
Cold store design, 0°C to -30°C**	●
DRIVE, LIFT CONTROLS	
Height and side-ways adjustable Flexi steering wheel	●
Finger tip controls for lifting/lowering	●
360-degree steering	●
Reversed steering	●
WHEEL OPTIONS	
Vulkollan	●
Tractothan	●
Super grip	●
OTHER OPTIONS	
High performance lift motor system 8.0 kW AC	●
Ergo Forks Trailing Control (EFTC)	●
Foot protection light barrier in driver compartment	●
Floor spot warning red or blue	●
Comfort and anti-slip floor mat in driver compartment (recommended)	●
Interactive multifunction display incl. BDI & hour meter, PIN code login (100 codes) and graphic icons	●
Foldable seat	●
Key switch entry (in combination with multifunction display)	●
Load weight indicator	●
Lift height indicator	●
Level assistance system	●
Panoramic ProVision OHG roof	●
12 V DC Power Socket	●
5 V USB socket	●
Accessory rack	●
Writing desk incl. RAM C holder	●
Accessory rack holder RAM system size C	●
Accessory rack holder RAM system size C, 2 pcs	●
Accessory rack holder RAM size D	●
Working lights LED	●
Special RAL colour	●

* Li-ion battery option is available in selected regions.
 ** Li-ion battery option not in combination with cold store design, 0°C to -30°C.

Continuing improvement may lead to changes in these specifications

AXIA XL

SBR12N2TF

STAND-IN STACKER WITH TELESCOPIC FORKS

1.2 tonnes



Standard display



Storage compartment under armrest



Foldable seat

WHEN RELIABILITY IS EVERYTHING...



AXiA
THE ALL ROUNDER

With a name that reflects its manoeuvrability, AXiA combines award-winning ergonomics with high performance and low-maintenance features to deliver a complete warehouse support package.

Efficient, versatile and durable, AXiA is the perfect choice for every workplace.

Like any product bearing the Mitsubishi Forklift Trucks name, our materials handling equipment benefits from the tremendous heritage, huge resources and cutting-edge technology of one of the world's largest corporations – Mitsubishi Heavy Industries Group.

Engineering spacecraft, jet planes, power plants and more, MHI specialises in those technologies where performance, dependability and superiority decide your success or failure...

So when we promise you quality, reliability and value for money, you know it's a guarantee we have the power to deliver.

That's why every model in our award winning and comprehensive range of lift trucks and warehouse equipment is built to a high specification – to ensure it keeps working for you. Day after day. Year after year. Whatever the job. Whatever the conditions.

YOU'LL NEVER WORK ALONE

As your local authorised distributor, we are here to keep your trucks working – through our extensive experience, our technical excellence and our commitment to customer care.

We are your local experts, backed by efficient channels to the entire organisation of Mitsubishi Forklift Trucks.

No matter where you are, we are close by – with the capability to meet your needs.

Discover how Mitsubishi Forklift Trucks give you more from your local authorised distributor or when you visit our website www.mitforklift.com

Performance specifications may vary depending on standard manufacturing tolerances, vehicle condition, types of tyres, floor or surface conditions, applications or operating environment. Trucks may be shown with non-standard options.

Specific performance requirements and locally available configurations should be discussed with your distributor.

We follow a policy of continual product improvement. For this reason, some materials, options and specifications could change without notice.

QUALITY | RELIABILITY | VALUE FOR MONEY

info@mitforklift.com

CESM2408 (11/23) © 2023 MLE

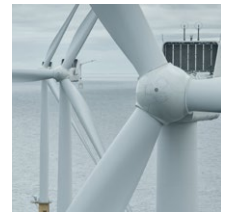

Mitsubishi Logisnext Europe B.V.
Hefbrugweg 77, 1332 AM Almere
The Netherlands
Tel: +31 (0)36 5494 411



mft2.eu/fb



mft2.eu/apps



mft2.eu/youtube



mft2.eu/facebook

